

**CANTONI**  
**MOTOR**

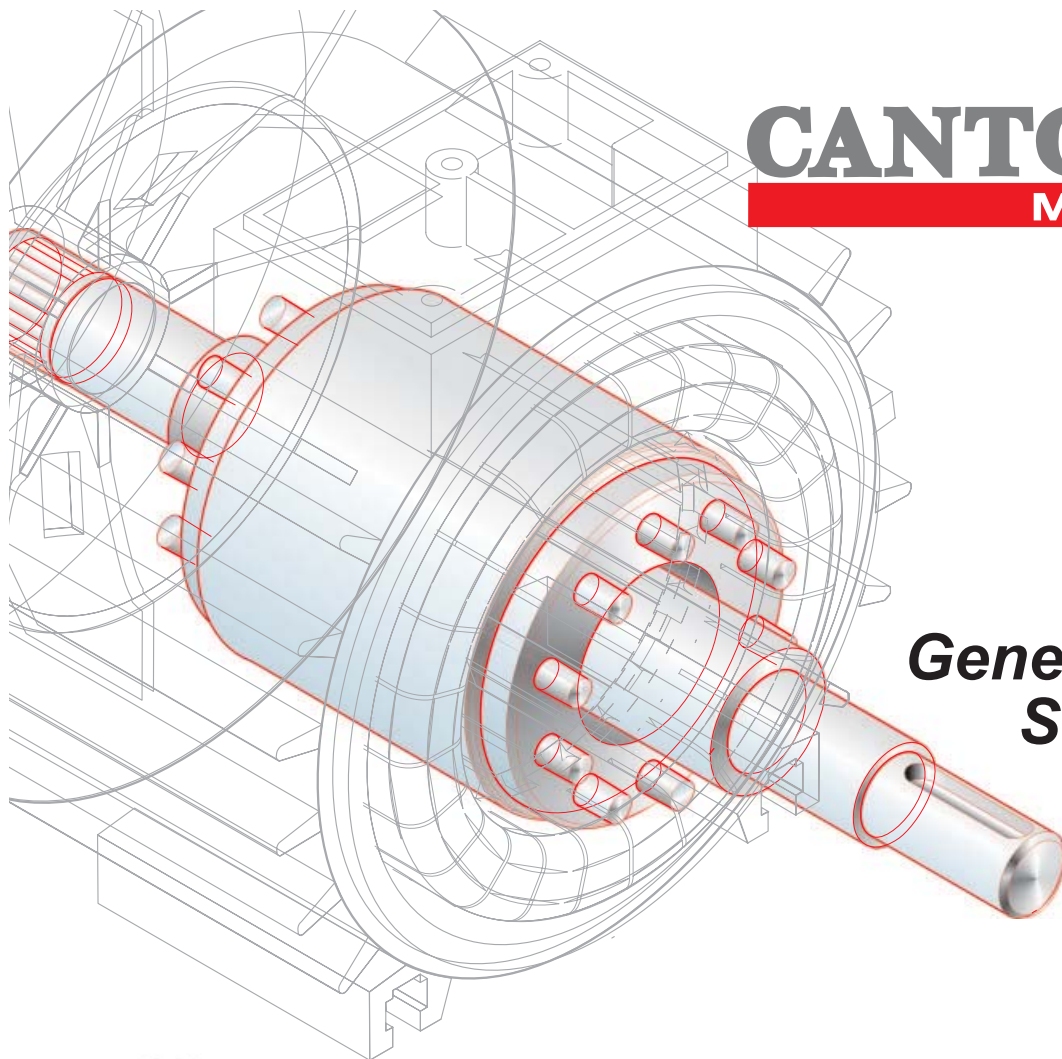

**General Purpose  
Single Phase  
Induction  
Motors**



# Cantoni<sup>®</sup>

**GROUP**

**Cantoni Motor S.A.**  
M. Grażyńskiego 22, 43-300 Bielsko-Biała, Poland  
tel.: +48 33 813 87 00  
fax: +48 33 813 87 01  
[motor@cantonigroup.com](mailto:motor@cantonigroup.com)  
[www.cantonimotor.com](http://www.cantonimotor.com)



*since 1950*



*since 1878*



*since 1954*



*since 1920*



*since 1921*

## DESCRIPTION OF THE CATALOGUE VERSION

All the motors are manufactured in Quality Assurance System consistent with ISO 9001.

Application:	general industrial
Duty:	S1
Degree of protection:	IP 55
Rated voltage:	230 V
Frequency:	50 Hz
Ambient temperature:	from -15°C to + 40°C
Mounting height:	up to 1000 m above sea level
Insulation class:	F



## DESCRIPTION OF THE CUSTOMIZED VERSION

The motors covered by the present catalogue comply with the regulations and standard effective in other countries, consistent with IEC standards.

Other supply voltage	
Frequency:	60 Hz
Degree of protection:	IP 56, IP 65, IP 66
Insulation class:	H
Tropicalization	
Other duty type	
Other versions per customer's specifications	
Capacitor placed in plastic covering box	



All the motors described in the present catalogue are provided with CE mark. It means that our products are consistent with the European Union directives regarding the safety measures.

## BEARINGS

Frame size	DE Bearing	NDE Bearing
SE(M)g 56	6201 2Z	6201 2Z
SE(M)g 63	6202 2Z	6202 2Z
SE(M)h 71	6203 2Z	6203 2Z
SE(M)h 80	6204 2Z	6204 2Z
SE(M)h 90	6205 2Z	6204 2Z
SE(M)hR 90	6205 2Z	6205 2Z

## MECHANICAL DESIGN

The frame, bearing shields, feet and terminal box are AK11 aluminium alloy cast. The fan is made of thermoplastic material, the fan cover is made of steel. Squirrel cages of standard starting torque motors are A1 aluminium cast, the rotors for increased starting torque are special aluminium alloy cast AK 121 (siluminum).

## FEATURES

Single phase motors are manufactured within the range of frame size 56-90 as:

- motors with standard starting torque (with capacitor run),
- motors with increased starting torque (with capacitor run and specially adjusted parameters),
- motors with high starting torque (with capacitor run, capacitor start and centrifugal switch).

## ORDER DATA

Motors in frame sizes 100 and 112 are available on request.

When placing an order, the following motor data should be given:
full motor type designation,
rated output,
rated speed,
operation duty,
voltage and frequency,
mounting arrangement,
degree of protection,
any special requirements.

*As part of our development program, we reserve the right to alter or amend any of the specifications without giving prior notice.*

## BASIC CONNECTION DIAGRAMS

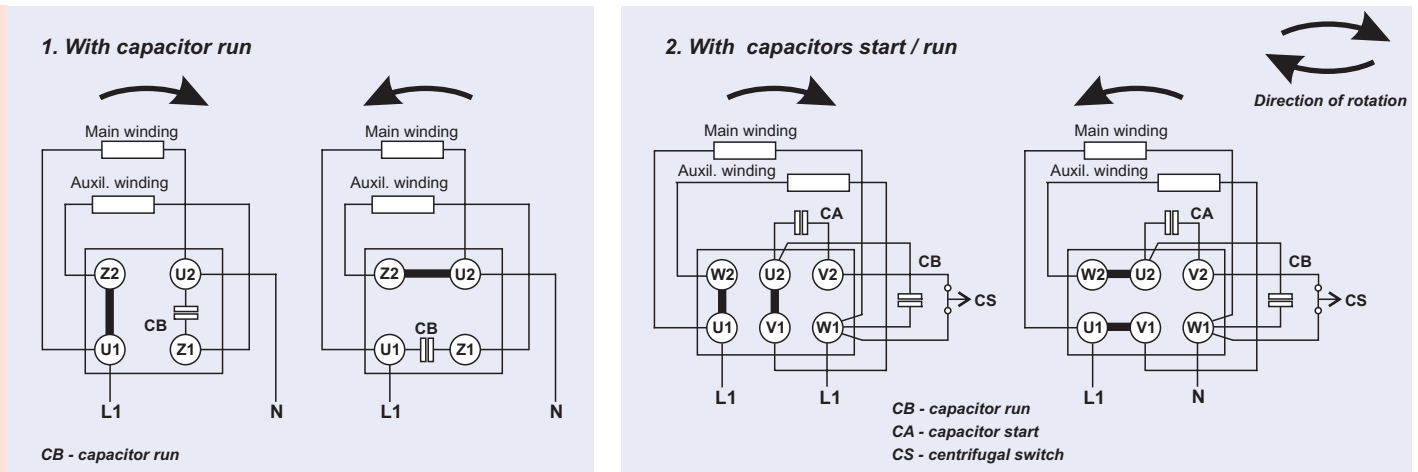

## OVERLOAD PROTECTION SETTINGS

Motor type	Maximal current at no load operation of the motor at: 230V; 50Hz	Rated current given on the motor name plate at: 230V; 50Hz	Maximal current at the rated load at: 230V; 50Hz	Recommended setting of the current for the overload protection of the motor at: 230V; 50Hz
	$I_o$ (max) [A]	$I_N$ [A]	$I_N$ (max) [A]	$I_{Np}$ [A]
SEg 56-2A	0,8	0,9	1,0	1,1
SEg 56-2B	0,8	1,0	1,12	1,2
SEg 56-2C	1,2	1,5	1,65	1,85
SEMg 56-2A	0,6	0,7	0,86	1,0
SEMg 56-2B	0,8	0,85	1,0	1,15
SEMg 56-2C	1,15	1,2	1,42	1,45
SEg 56-4A	0,55	0,6	0,69	0,75
SEg 56-4B	0,83	0,85	0,94	1,0
SEMg 56-4A	0,55	0,5	0,6	0,65
SEMg 56-4B	0,95	0,85	1,14	1,2
SEMg 56-4C	1,1	1,1	1,2	1,25
SEg 63-2A	1,35	1,45	1,65	1,75
SEg 63-2B	1,8	1,85	2,03	2,25
SEg 63-2C	2,0	2,5	2,64	2,7
SEMg 63-2A	1,2	1,3	1,35	1,4
SEMg 63-2B	1,8	1,8	2,16	2,2
SEMg 63-2C	1,95	2,0	2,14	2,45
SEg 63-4A	1,1	1,2	1,39	1,45
SEg 63-4B	1,3	1,5	1,6	1,7
SEg 63-4C	1,65	1,9	2,05	2,2
SEMg 63-4A	1,0	1,1	1,33	1,4
SEMg 63-4B	1,2	1,25	1,36	1,45
SEMg 63-4C	1,7	1,72	2,05	2,1
SEh 71-2B	3,2	3,6	3,9	4,3
SEh 71-2C	2,4	4,9	5,33	5,6
SEMh 71-2B	2,8	3,0	3,26	3,6
SEMh 71-2C	3,1	3,6	3,93	4,2
SEh 71-4A	2,0	2,4	2,82	3,4
SEh 71-4B	2,3	2,9	3,2	3,55
SEh 71-4C	3,3	4,2	4,64	5,0
SEMh 71-4B	2,0	2,3	2,48	2,85
SEMh 71-4C	2,9	3,2	3,69	3,8
SEh 80-2B	3,7	7,0	7,55	7,8
SEh 80-2C	3,0	9,1	9,75	11,0
SEh 80-4B	2,9	4,9	5,35	5,5
SEh 80-4C	5,4	7,2	7,75	8,3
SEMh 80-2B	4,0	5,0	5,41	5,6
SEMh 80-2C	4,6	6,4	6,9	7,6
SEMh 80-4B	3,75	3,9	4,27	4,4
SEMh 80-4C	4,9	5,6	6,2	6,3
SEh 90-2S	3,5	9,0	9,55	10,0
SEh 90-2L	4,0	13,0	13,3	13,6
SEMh 90-2S	3,5	7,0	7,5	8,0
SEMh 90-2L	4,2	10,0	10,0	11,0
SEh 90-4S	5,4	7,2	7,75	8,2
SEh 90-4L	5,0	9,0	9,6	10,0
SEMh 90-4S	4,9	5,6	6,2	6,6
SEMh 90-4L	5,8	7,8	8,52	8,9

Current values given in a column 3 are stated on the rating plates.

Column 4 presents the maximal current values that can occur with the rated load for the rated efficiency and power factor deviations according to the standards.

Column 5 covers the values recommended for the setting switches used by the customers for the overload protection of the motor.

Item	Motor Type	Rated Output P <sub>N</sub>		Rated Speed n <sub>N</sub> [rpm]	Full Load Current at 230V I <sub>N</sub> [A]	Efficiency η [%]	Power Factor cos φ <sub>N</sub>	Rated Torque T <sub>N</sub> [Nm]	Locked Rotor Current I <sub>L</sub> / I <sub>N</sub>	Locked Rotor Torque T <sub>L</sub> / T <sub>N</sub>	Breakdown Torque T <sub>b</sub> / T <sub>N</sub>	Moment of Inertia J [kgm <sup>2</sup> ]	Capacitor Run C <sub>B</sub> 450V [μF]	Capacitor Start C <sub>A</sub> 450V [μF]	Weight IMB3 m [kg]
		[kW]	[HP]												
<b>STANDARD STARTING TORQUE MOTORS</b>															
1.	SEg 56-2A	0,09	0,12	2840	0,90	55	0,88	0,303	2,8	0,5	1,6	0,00007	3	-	3
2.	SEg 56-2B	0,12	0,17	2860	1	61	0,92	0,4	3,1	0,45	1,5	0,00009	5	-	3,5
3.	SEg 56-2C	0,18	0,25	2800	1,5	62	0,89	0,614	2,6	0,4	1,6	0,0001	6	-	3,9
4.	SEg 63-2A	0,18	0,25	2820	1,45	57	0,95	0,61	2,6	0,55	1,7	0,000175	8	-	3,8
5.	SEg 63-2B	0,25	0,33	2850	1,85	63	0,94	0,84	3,1	0,5	1,7	0,000235	10	-	4,4
6.	SEg 63-2C	0,37	0,5	2820	2,5	69	0,98	1,26	3,5	0,4	1,5	0,00031	12	-	5,2
7.	SEh 71-2B	0,55	0,75	2820	3,6	70	0,96	1,86	3	0,36	1,6	0,00053	14	-	6,3
8.	SEh 71-2C	0,75	1	2820	4,9	71	0,98	2,54	3	0,4	1,5	0,000691	25	-	7,7
9.	SEh 80-2B	1,1	1,5	2780	7	72	0,97	3,78	2,7	0,4	1,4	0,00111	25	-	9,8
10.	SEh 80-2C	1,5	2	2740	9,1	73	0,99	5,23	2,7	0,5	1,5	0,00142	40	-	11,8
11.	SEh 80-2D	2,0	2,8	2780	13	74	0,99	6,87	2,5	0,4	1,4	0,0021	50	-	15,2
12.	SEh 90-2S	1,5	2	2800	9	77	0,99	5,12	3,3	0,4	1,6	0,0012	40	-	12,4
13.	SEh 90-2L	2	2,8	2780	13	74	0,99	6,87	2,5	0,4	1,4	0,0016	50	-	15,2
14.	SEhR 90-2S	1,5	2,00	2800	9	75	0,97	5,12	3	0,45	1,6	0,0012	40	-	12,4
15.	SEhR 90-2L	2,2	3	2810	12,8	76	0,99	7,48	2,5	0,38	1,4	0,0016	50	-	15,2
16.	SEhR 90-2M	2,7	3,6	2840	16	79	0,98	9,1	3,8	0,36	1,6	0,00244	60	-	18
<b>INCREASED STARTING TORQUE MOTORS</b>															
17.	SEMg 56-2A	0,06	0,08	2800	0,7	50	0,78	0,205	2,4	1	2,3	0,00007	3	-	3,1
18.	SEMg 56-2B	0,09	0,12	2790	0,85	53	0,87	0,308	2,5	1	2,0	0,00009	5	-	3,5
19.	SEMg 56-2C	0,12	0,17	2800	1,20	54	0,82	0,409	3	0,9	2	0,0001	5	-	3,8
20.	SEMg 63-2A	0,12	0,17	2750	1,3	52	0,83	0,417	2,4	0,9	1,9	0,000175	6	-	3,9
21.	SEMg 63-2B	0,18	0,25	2760	1,8	52	0,84	0,623	2,7	0,8	2	0,000235	8	-	4,4
22.	SEMg 63-2C	0,25	0,33	2800	2	63	0,90	0,853	3,1	0,8	2	0,00031	10	-	5,2
23.	SEmh 71-2A	0,25	0,33	2720	2	57	0,97	0,88	2,3	0,8	1,7	0,00039	10	-	5,2
24.	SEmh 71-2B	0,37	0,5	2800	3	64	0,84	1,262	2,7	0,7	1,8	0,000536	12	-	6,4
25.	SEmh 71-2C	0,55	0,75	2780	3,6	70	0,98	1,889	3,2	0,65	1,6	0,000691	20	-	7,7
26.	SEmh 80-2A	0,55	0,75	2780	4,1	67	0,84	1,89	3	0,7	1,8	0,0008	20	-	8
27.	SEmh 80-2B	0,75	1	2800	5	70	0,94	2,56	3,4	0,65	1,9	0,00111	25	-	9,7
28.	SEmh 80-2C	1,1	1,5	2780	6,4	76	0,98	3,75	3,5	0,55	1,8	0,00142	30	-	11,7
29.	SEmh 80-2D	1,5	2	2700	10,2	71	0,90	5,31	2,8	0,7	1,6	0,0021	40	-	13,5
30.	SEmh 90-2S	1,1	1,5	2760	7	74	0,98	3,81	3	0,55	1,6	0,0012	30	-	12,4
31.	SEmh 90-2L	1,5	2	2700	10,2	71	0,90	5,31	2,8	0,7	1,6	0,0016	40	-	15,2
32.	SEmhR 90-2S	1,1	1,5	2760	7	74	0,98	3,80	3,2	0,6	1,6	0,0012	30	-	12,4
33.	SEmhR 90-2L	1,5	2	2750	9,4	72	0,97	5,02	3,5	0,7	1,6	0,0016	40	-	15,2
<b>HIGH STARTING TORQUE MOTORS</b>															
34.	Seg 63-2AF	0,18	0,25	2820	1,5	57	0,95	0,61	4	1,8	1,7	0,000175	8	25	4
35.	SEg 63-2BF	0,25	0,33	2850	1,85	66	0,94	0,838	4,1	1,9	1,9	0,000235	10	30	4,6
36.	SEg 63-2CF	0,37	0,5	2850	2,45	72	0,95	1,24	4,5	1,7	1,6	0,00031	12	40	5,4
37.	SEh 71-2BF	0,55	0,75	2820	3,6	70	0,96	1,86	3,6	1,7	1,6	0,00053	14	25	6,5
38.	SEh 71-2CF	0,75	1	2820	4,9	71	0,98	2,54	4	1,7	1,5	0,000691	25	70	8,1
39.	SEh 80-2BF	1,1	1,5	2780	7	72	0,97	3,78	3,5	1,7	1,4	0,00111	25	70	10,6
40.	SEh 80-2CF	1,5	2	2800	9,5	75	0,96	5,12	3,7	1,9	1,7	0,00142	40	60	12,2
41.	SEh 90-2SF	1,5	2	2800	9	77	0,99	5,12	3,6	1,7	1,6	0,0012	40	60	13,5
42.	SEh 90-2LF	2	2,8	2780	13	74	0,99	6,87	3,5	1,6	1,4	0,0016	50	75	16,3
43.	SEhR 90-2SF	1,5	2	2800	9	77	0,99	5,12	4,1	1,9	1,6	0,0012	40	120	12,8
44.	SEhR 90-2LF	2,2	3	2810	12,8	76	0,99	7,48	3,8	1,7	1,7	0,0016	50	200	15,5
45.	SEhR 90-2MF	2,7	3,6	2840	16	79	0,98	9,1	4,2	2,0	1,6	0,0024	60	200	18,5

TECHNICAL DATA

TOTALLY ENCLOSED MOTORS IP 55

230 V

Item	Motor Type	Rated Output P <sub>N</sub>		Rated Speed n <sub>N</sub> [rpm]	Full Load Current at 230V I <sub>N</sub> [A]	Efficiency η [%]	Power Factor cos φ <sub>N</sub>	Rated Torque T <sub>N</sub> [Nm]	Locked Rotor Current I <sub>L</sub> /I <sub>N</sub>	Locked Rotor Torque T <sub>L</sub> /T <sub>N</sub>	Breakdown Torque T <sub>b</sub> /T <sub>N</sub>	Moment of Inertia J [kgm <sup>2</sup> ]	Capacitor Run C <sub>B</sub> 450V [μF]	Capacitor Start C <sub>A</sub> 450V [μF]	Weight mB3 m [kg]
		[kW]	[HP]												
<b>STANDARD STARTING TORQUE MOTORS</b>															
46.	SEg 56-4A	0,06	0,08	1410	0,6	50	0,9	0,406	2	0,55	1,55	0,0002	3	-	3,1
47.	SEg 56-4B	0,09	0,12	1420	0,85	56	0,9	0,605	2,4	0,60	1,60	0,00025	4	-	3,5
48.	SEg 63-4A	0,12	0,17	1400	1,2	50	0,9	0,819	2,2	0,65	1,45	0,00024	6	-	3,8
49.	SEg 63-4B	0,18	0,25	1400	1,5	57	0,95	1,228	2,3	0,65	1,50	0,000307	8	-	4,3
50.	SEg 63-4C	0,25	0,33	1400	1,9	64	0,92	1,705	2,6	0,5	1,45	0,00038	10	-	5,1
51.	SEh 71-4A	0,25	0,33	1350	2,4	50	0,92	1,77	2	0,35	1,4	0,00061	8	-	5,3
52.	SEh 71-4B	0,37	0,5	1370	2,9	64	0,87	2,598	2,1	0,5	1,4	0,000852	10	-	6,3
53.	SEh 71-4C	0,55	0,75	1350	4,2	65	0,92	3,89	2,2	0,4	1,4	0,001099	18	-	6,3
54.	SEh 80-4A	0,55	0,75	1380	3,9	68	0,90	3,81	2,6	0,45	1,4	0,00157	16	-	9,6
55.	SEh 80-4B	0,75	1	1370	4,9	70	0,95	5,23	2,5	0,4	1,3	0,00208	20	-	9,6
56.	SEh 80-4C	1,1	1,5	1370	7,2	72	0,93	7,67	2,6	0,4	1,4	0,002652	30	-	11,4
57.	SEh 80-4D	1,3	2	1370	9,0	72	0,90	9,1	2,8	0,4	1,4	0,0019	40	-	14
58.	SEh 90-4S	1,1	1,5	1370	7,2	72	0,93	7,7	2,6	0,4	1,4	0,0024	30	-	12,3
59.	SEh 90-4L	1,3	1,8	1370	9	72	0,91	9,1	2,8	0,38	1,4	0,0032	40	-	14
60.	SEhR 90-4S	1,1	1,5	1380	7,5	70	0,96	7,6	2,5	0,4	1,4	0,0024	30	-	12
61.	SEhR 90-4L	1,5	2	1400	9,3	76	0,97	10,2	3	0,4	1,5	0,0032	35	-	15
62.	SEhR 90-4M	2,2	3	1380	14,7	70	0,96	15,2	3,5	0,4	1,5	0,0046	50	-	17,8
<b>INCREASED STARTING TORQUE MOTORS</b>															
63.	SEMg 56-4A	0,04	0,06	1390	0,5	40	0,84	0,275	2	1,4	2,1	0,0002	3	-	3,1
64.	SEMg 56-4B	0,06	0,08	1390	0,85	39	0,80	0,412	2,1	1,3	2,5	0,00025	4	-	3,3
65.	SEMg 56-4C	0,09	0,12	1360	1,1	50	0,83	0,632	2	1,1	1,8	0,0003	5	-	4
66.	SEMg 63-4A	0,09	0,12	1350	1,1	44	0,85	0,632	1,9	1,1	1,7	0,00024	5	-	3,8
67.	SEMg 63-4B	0,12	0,17	1360	1,25	53	0,86	0,843	2,2	1	1,9	0,000307	6	-	4,3
68.	SEMg 63-4C	0,18	0,25	1350	1,72	58	0,78	1,273	2,3	0,8	1,6	0,00038	8	-	5,1
69.	SEMh 71-4B	0,25	0,33	1340	2,3	60	0,87	1,782	2	1	1,7	0,000852	10	-	6,3
70.	SEMh 71-4C	0,37	0,5	1340	3,0	63	0,88	2,64	2,3	0,8	1,5	0,001099	14	-	7,4
71.	SEMh 80-4A	0,37	0,5	1350	3,0	64	0,85	2,62	2,3	0,9	1,8	0,00156	14	-	8,3
72.	SEMh 80-4B	0,55	0,75	1360	3,9	68	0,91	3,86	3,2	0,6	1,6	0,00208	20	-	9,6
73.	SEMh 80-4C	0,75	1	1340	5,6	65	0,9	5,35	2,5	0,65	1,5	0,002652	25	-	11,4
74.	SEMh 90-4S	0,75	1	1400	5,6	65	0,9	5,19	3	0,65	1,6	0,0024	25	-	12,3
75.	SEMh 90-4L	1,1	1,5	1300	7,8	67	0,92	8,08	2,2	0,5	1,4	0,0032	40	-	14,5
76.	SEMhR 90-4S	0,75	1	1380	5,5	66	0,95	5,2	3,1	0,6	1,6	0,0024	25	-	12
77.	SEMhR 90-4L	1,1	1,5	1360	8,1	65	0,95	7,7	2,6	0,6	1,5	0,0032	30	-	15
78.	SEMhR 90-4M	1,5	2	1340	11,0	63	0,98	10,7	2,5	0,7	1,5	0,0046	40	-	17,5
<b>HIGH STARTING TORQUE MOTORS</b>															
79.	SEg 63-4AF	0,12	0,17	1400	1,1	54	0,92	0,82	3,3	1,7	1,6	0,00024	6	14	3,8
80.	SEg 63-4BF	0,18	0,25	1400	1,45	60	0,95	1,2	3,2	1,5	1,5	0,000307	8	16	4,4
81.	SEg 63-4CF	0,25	0,33	1400	1,8	68	0,92	1,71	3,3	1,6	1,4	0,00038	10	20	5,2
82.	SEh 71-4BF	0,37	0,5	1370	2,5	62	0,88	2,6	3,5	1,8	1,3	0,000852	10	25	6,5
83.	SEh 71-4CF	0,55	0,75	1350	4,2	64	0,92	3,89	3,6	1,9	1,4	0,00101	18	60	8
84.	SEh 80-4BF	0,75	1	1370	4,9	70	0,95	5,23	3	1,8	1,4	0,00208	20	60	10,4
85.	SEh 80-4CF	1,1	1,5	1400	7,4	74	0,91	7,5	3,6	1,9	1,5	0,00265	30	75	12,2
86.	SEh 90-4SF	1,1	1,5	1400	7,5	73	0,90	7,5	4	1,6	1,5	0,0024	30	75	13,7
87.	SEh 90-4LF	1,3	1,8	1360	9	72	0,91	9,13	3,2	1,8	1,4	0,0032	40	90	14,8
88.	SEhR 90-4SF	1,1	1,5	1380	7,5	70	0,96	7,6	3,8	1,6	1,4	0,0024	25	100	12,4
89.	SEhR 90-4LF	1,5	2	1400	9,3	76	0,97	10,2	4	1,7	1,5	0,0032	35	160	15,4
90.	SEhR 90-4MF	2,2	3	1380	14,7	70	0,96	15,2	4,2	2	1,5	0,0046	50	160	17,8

TECHNICAL DATA



FOOT MOUNTED MOTORS - IM B3

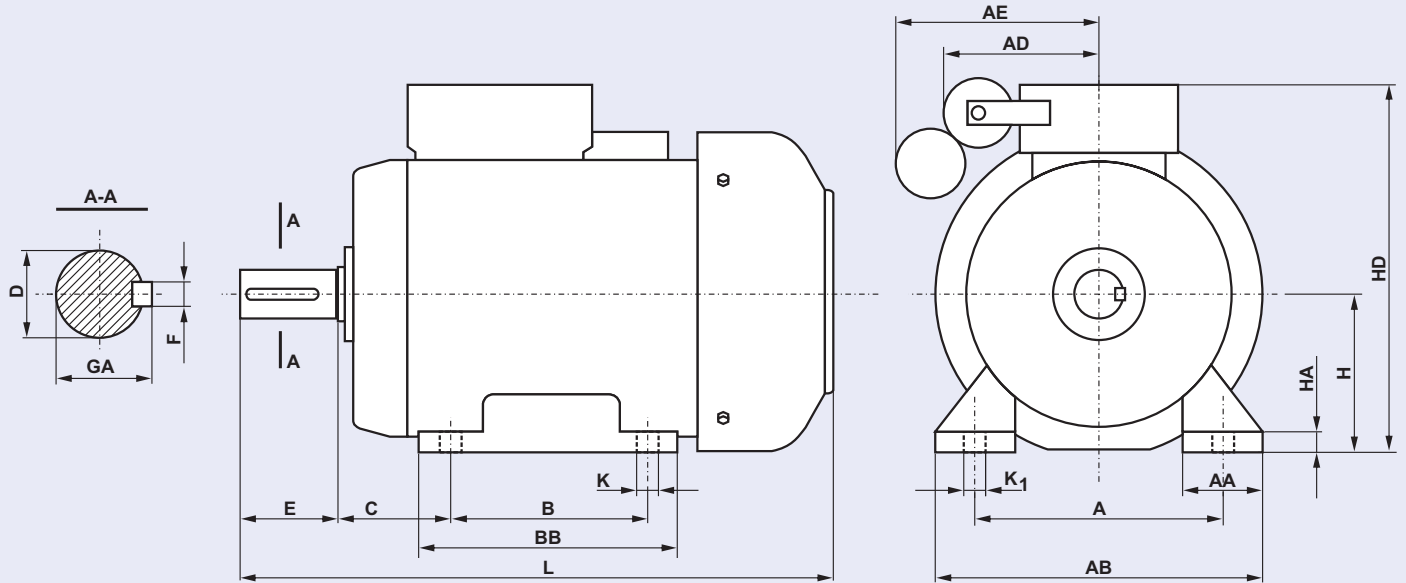

Motor Type	A	B	C	D	E	F	GA	H	K	K1	HA	AA	AB	BB	AE	AD	HD	L
SE(M)g56-A	90	71	36	9j6	20	3h9	10,2	56	5,8	8	7	30	110	92	-	74	154	188
SE(M)g56-B	90	71	36	9j6	20	3h9	10,2	56	5,8	8	7	30	110	92	-	74	154	196
SE(M)g56-C	90	71	36	9j6	20	3h9	10,2	56	5,8	8	7	30	110	92	-	74	154	204
SE(M)g63-A	100	80	40	11j6	23	4h9	12,5	63	7	10	8,5	36	124	106	-	74	165	202
SEg63-AF	100	80	40	11j6	23	4h9	12,5	63	7	10	8,5	36	124	106	100	74	165	245
SE(M)g63-B	100	80	40	11j6	23	4h9	12,5	63	7	10	8,5	36	124	106	-	74	165	214
SEg63-BF	100	80	40	11j6	23	4h9	12,5	63	7	10	8,5	36	124	106	100	74	165	257
SE(M)g63-C	100	80	40	11j6	23	4h9	12,5	63	7	10	8,5	36	124	106	-	74	165	228
SEg63-CF	100	80	40	11j6	23	4h9	12,5	63	7	10	8,5	36	124	106	100	74	165	271
SE(M)h71-A	112	90	45	14j6	30	5h9	16	71	7	10	8	45	142	116	-	90	182	223
SE(M)h71-B	112	90	45	14j6	30	5h9	16	71	7	10	8	45	142	116	-	90	182	245
SEh71-BF	112	90	45	14j6	30	5h9	16	71	7	10	8	45	142	116	100	90	182	285
SE(M)h71-C	112	90	45	14j6	30	5h9	16	71	7	10	8	45	142	116	-	90	182	263
SEh71-CF	112	90	45	14j6	30	5h9	16	71	7	10	8	45	142	116	100	90	182	303
SE(M)h80-A	125	100	50	19j6	40	6h9	21,5	80	10	13	9	55	160	130	-	95	200	266
SE(M)h80-B	125	100	50	19j6	40	6h9	21,5	80	10	13	9	55	160	130	-	95	200	278
SEh80-BF	125	100	50	19j6	40	6h9	21,5	80	10	13	9	55	160	130	120	95	200	315
SE(M)h80-C	125	100	50	19j6	40	6h9	21,5	80	10	13	9	55	160	130	-	95	200	306
SEh80-CF	125	100	50	19j6	40	6h9	21,5	80	10	13	9	55	160	130	120	95	200	343
SE(M)h80-D	125	100	50	19j6	40	6h9	21,5	80	10	13	9	55	160	130	-	95	200	324
SE(M)h90-S	140	100	56	24j6	50	8h9	27	90	10	13	12	60	170	153	-	95	208	316
SEh90-SF	140	100	56	24j6	50	8h9	27	90	10	13	12	60	170	153	120	95	208	350
SE(M)h90-L	140	125	56	24j6	50	8h9	27	90	10	13	12	60	170	153	-	95	208	328
SEh90-LF	140	125	56	24j6	50	8h9	27	90	10	13	12	60	170	153	120	95	208	364
SE(M)hR90-S	140	100	56	24j6	50	8h9	27	90	10	13	12	69	182	153	-	95	210	312
SEhR90-SF	140	100	56	24j6	50	8h9	27	90	10	13	12	69	182	153	120	95	210	352
SE(M)hR90-L	140	125	56	24j6	50	8h9	27	90	10	13	12	69	182	178	-	95	210	337
SEhR90-LF	140	125	56	24j6	50	8h9	27	90	10	13	12	69	182	178	120	95	210	377
SE(M)hR90-M	140	125	56	24j6	50	8h9	27	90	10	13	12	69	182	198	-	95	210	357
SEhR90-MF	140	125	56	24j6	50	8h9	27	90	10	13	12	69	182	198	120	95	210	397

DIMENSION DRAWINGS

FLANGE MOUNTED MOTORS - IM B5

DIMENSION DRAWINGS

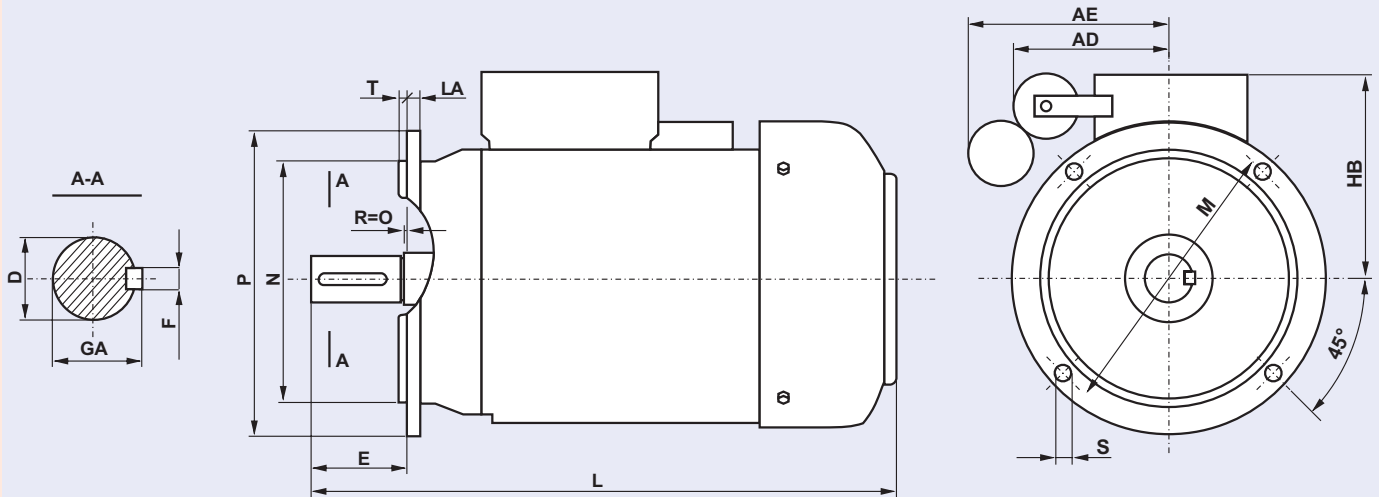

Motor Type	Flange	P	M	N	S	D	E	F	GA	LA	T	AE	AD	HB	L
SE(M)Kg56-A	B5	120	100	80j6	7	9j6	20	3h9	10,2	8	3	-	74	98	188
SE(M)Kg56-B	B5	120	100	80j6	7	9j6	20	3h9	10,2	8	3	-	74	98	196
SE(M)Kg56-C	B5	120	100	80j6	7	9j6	20	3h9	10,2	8	3	-	74	98	204
SE(M)Kg63-A	B5	140	115	95j6	10	11j6	23	4h9	12,5	9	3	-	74	102	201
SEKg63-AF	B5	140	115	95j6	10	11j6	23	4h9	12,5	9	3	100	74	102	245
SE(M)Kg63-B	B5	140	115	95j6	10	11j6	23	4h9	12,5	9	3	-	74	102	213
SEKg63-BF	B5	140	115	95j6	10	11j6	23	4h9	12,5	9	3	100	74	102	257
SE(M)Kg63-C	B5	140	115	95j6	10	11j6	23	4h9	12,5	9	3	-	74	102	228
SEKg63-CF	B5	140	115	95j6	10	11j6	23	4h9	12,5	9	3	100	74	102	271
SE(M)Kh71-A	B5	160	130	110j6	10	14j6	30	5h9	16	9	3,5	-	90	111	223
SE(M)Kh71-B	B5	160	130	110j6	10	14j6	30	5h9	16	9	3,5	-	90	111	245
SEKh71-BF	B5	160	130	110j6	10	14j6	30	5h9	16	9	3,5	100	90	111	285
SE(M)Kh71-C	B5	160	130	110j6	10	14j6	30	5h9	16	9	3,5	-	90	111	263
SEKh71-CF	B5	160	130	110j6	10	14j6	30	5h9	16	9	3,5	100	90	111	303
SE(M)Kh80-A	B5	200	165	130j6	12	19j6	40	6h9	21,5	10	3,5	-	95	120	266
SE(M)Kh80-B	B5	200	165	130j6	12	19j6	40	6h9	21,5	10	3,5	-	95	120	278
SEKh80-BF	B5	200	165	130j6	12	19j6	40	6h9	21,5	10	3,5	120	95	120	315
SE(M)Kh80-C	B5	200	165	130j6	12	19j6	40	6h9	21,5	10	3,5	-	95	120	306
SEKh80-CF	B5	200	165	130j6	12	19j6	40	6h9	21,5	10	3,5	120	95	120	343
SE(M)Kh80-D	B5	200	165	130j6	12	19j6	40	6h9	21,5	10	3,5	-	95	120	324
SE(M)Kh90-S	B5	200	165	130j6	12	24j6	50	8h9	27	10	3,5	-	95	118	316
SEKh90-SF	B5	200	165	130j6	12	24j6	50	8h9	27	10	3,5	120	95	118	350
SE(M)Kh90-L	B5	200	165	130j6	12	24j6	50	8h9	27	10	3,5	-	95	118	328
SEKh90-LF	B5	200	165	130j6	12	24j6	50	8h9	27	10	3,5	120	95	118	364
SE(M)KhR90-S	B5	200	165	130j6	12	24j6	50	8h9	27	10	3,5	-	95	120	312
SEKhR90-SF	B5	200	165	130j6	12	24j6	50	8h9	27	10	3,5	120	95	120	352
SE(M)KhR90-L	B5	200	165	130j6	12	24j6	50	8h9	27	10	3,5	-	95	120	337
SEKhR90-LF	B5	200	165	130j6	12	24j6	50	8h9	27	10	3,5	120	95	120	377
SE(M)KhR90-M	B5	200	165	130j6	12	24j6	50	8h9	27	10	3,5	-	95	120	357
SEKhR90-MF	B5	200	165	130j6	12	24j6	50	8h9	27	10	3,5	120	95	120	397



FLANGE MOUNTED MOTORS - IM B14

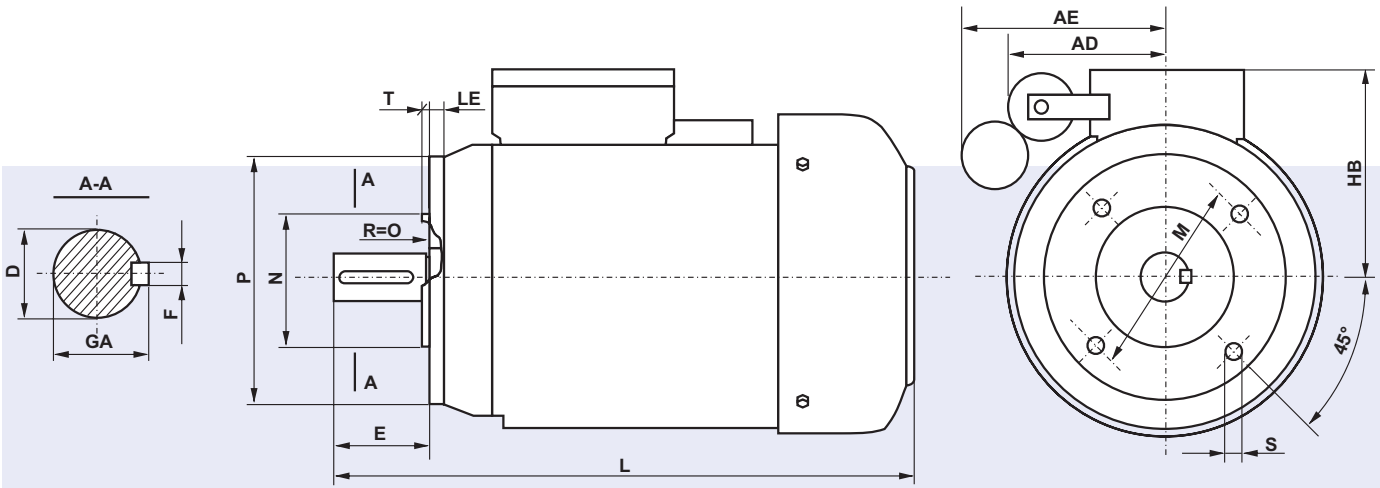

Motor Type	Flange	P	M	N	S	D	E	F	GA	LE	T	AE	AD	HB	L
SE(M)Kg56-A1	B14/C1	105	85	70j6	M6	9j6	20	3h9	10,2	15	2,5	-	74	98	188
SE(M)Kg56-A2	B14/C2	80	65	50j6	M5	9j6	20	3h9	10,2	12,5	2,5	-	74	98	188
SE(M)Kg56-B1	B14/C1	105	85	70j6	M6	9j6	20	3h9	10,2	15	2,5	-	74	98	196
SE(M)Kg56-B2	B14/C2	80	65	50j6	M5	9j6	20	3h9	10,2	12,5	2,5	-	74	98	196
SE(M)Kg56-C1	B14/C1	105	85	70j6	M6	9j6	20	3h9	10,2	15	2,5	-	74	98	204
SE(M)Kg56-C2	B14/C2	80	65	50j6	M5	9j6	20	3h9	10,2	12,5	2,5	-	74	98	204
SE(M)Kg63-A1	B14/C1	120	100	80j6	M6	11j6	23	4h9	12,5	14	3	-	74	102	201
SEKg63-AF1	B14/C1	120	100	80j6	M6	11j6	23	4h9	12,5	14	3	100	74	102	245
SE(M)Kg63-A2	B14/C2	90	75	60j6	M5	11j6	23	4h9	12,5	9,5	2,5	-	74	102	201
SEKg63-AF2	B14/C2	90	75	60j6	M5	11j6	23	4h9	12,5	9,5	2,5	100	74	102	245
SE(M)Kg63-B1	B14/C1	120	100	80j6	M6	11j6	23	4h9	12,5	14	3	-	74	102	213
SE(M)Kg63-B2	B14/C2	90	75	60j6	M5	11j6	23	4h9	12,5	9,5	2,5	-	74	102	213
SEKg63-BF2	B14/C2	90	75	60j6	M5	11j6	23	4h9	12,5	9,5	2,5	100	74	102	257
SE(M)Kg63-C1	B14/C1	120	100	80j6	M6	11j6	23	4h9	12,5	14	3	-	74	102	228
SEKg63-CF1	B14/C1	120	100	80j6	M6	11j6	23	4h9	12,5	14	3	100	74	102	271
SE(M)Kg63-C2	B14/C2	90	75	60j6	M5	11j6	23	4h9	12,5	9,5	2,5	-	74	102	228
SEKg63-CF2	B14/C2	90	75	60j6	M5	11j6	23	4h9	12,5	9,5	2,5	100	74	102	271
SE(M)Kh71-A1	B14/C1	140	115	95j6	M8	14j6	30	5h9	16	14	3	-	90	111	223
SE(M)Kh71-A2	B14/C2	105	85	70j6	M6	14j6	30	5h9	16	12	2,5	-	90	111	223
SE(M)Kh71-B1	B14/C1	140	115	95j6	M8	14j6	30	5h9	16	14	3	-	90	111	245
SEKh71-BF1	B14/C1	140	115	95j6	M8	14j6	30	5h9	16	14	3	100	90	111	285
SE(M)Kh71-B2	B14/C2	105	85	70j6	M6	14j6	30	5h9	16	12	2,5	-	90	111	245
SEKh71-BF2	B14/C2	105	85	70j6	M6	14j6	30	5h9	16	12	2,5	100	90	111	285
SE(M)Kh71-C1	B14/C1	140	115	95j6	M8	14j6	30	5h9	16	14	3	-	90	111	263
SEKh71-CF1	B14/C1	140	115	95j6	M8	14j6	30	5h9	16	14	3	100	90	111	303
SE(M)Kh71-C2	B14/C2	105	85	70j6	M6	14j6	30	5h9	16	12	2,5	-	90	111	263
SEKh71-CF2	B14/C2	105	85	70j6	M6	14j6	30	5h9	16	12	2,5	100	90	111	303
SE(M)Kh80-A1	B14/C1	160	130	110j6	M8	19j6	40	6h9	21,5	14	3,5	-	95	120	266
SE(M)Kh80-A2	B14/C2	120	100	80j6	M6	19j6	40	6h9	21,5	12	3	-	95	120	266
SE(M)Kh80-B1	B14/C1	160	130	110j6	M8	19j6	40	6h9	21,5	14	3,5	-	95	120	278
SEKh80-BF1	B14/C1	160	130	110j6	M8	19j6	40	6h9	21,5	14	3,5	120	95	120	315
SE(M)Kh80-B2	B14/C2	120	100	80j6	M6	19j6	40	6h9	21,5	12	3	-	95	120	278
SEKh80-BF2	B14/C2	120	100	80j6	M6	19j6	40	6h9	21,5	12	3	120	95	120	315
SE(M)Kh80-C1	B14/C1	160	130	110j6	M8	19j6	40	6h9	21,5	14	3,5	-	95	120	306
SEKh80-CF1	B14/C1	160	130	110j6	M8	19j6	40	6h9	21,5	14	3,5	120	95	120	343
SE(M)Kh80-C2	B14/C2	120	100	80j6	M6	19j6	40	6h9	21,5	12	3	-	95	120	306
SEKh80-CF2	B14/C2	120	100	80j6	M6	19j6	40	6h9	21,5	12	3	120	95	120	343
SE(M)Kh80-D1	B14/C1	160	130	110j6	M8	19j6	40	6h9	21,5	14	3,5	-	95	120	324
SE(M)Kh80-D2	B14/C2	120	100	80j6	M6	19j6	40	6h9	21,5	12	3	-	95	120	324
SE(M)Kh90-S1	B14/C1	160	130	110j6	M8	24j6	50	8h9	27	10	3,5	-	95	118	316
SEKh90-SF1	B14/C1	160	130	110j6	M8	24j6	50	8h9	27	10	3,5	120	95	118	350
SE(M)Kh90-S2	B14/C2	140	115	95j6	M8	24j6	50	8h9	27	10	3	-	95	118	316
SEKh90-SF2	B14/C2	140	115	95j6	M8	24j6	50	8h9	27	10	3	120	95	118	350
SE(M)Kh90-L1	B14/C1	160	130	110j6	M8	24j6	50	8h9	27	10	3,5	-	95	118	328
SEKh90-LF1	B14/C1	160	130	110j6	M8	24j6	50	8h9	27	10	3,5	120	95	118	364
SE(M)Kh90-L2	B14/C2	140	115	95j6	M8	24j6	50	8h9	27	10	3	-	95	118	328
SEKh90-LF2	B14/C2	140	115	95j6	M8	24j6	50	8h9	27	10	3	120	95	118	364
SE(M)KhR90-S1	B14/C1	160	130	110j6	M8	24j6	50	8h9	27	10	3,5	-	95	120	312
SEKh90-SF1	B14/C1	160	130	110j6	M8	24j6	50	8h9	27	10	3,5	120	95	120	352
SE(M)KhR90-S2	B14/C2	140	115	95j6	M8	24j6	50	8h9	27	10	3	-	95	120	312
SEKh90-SF2	B14/C2	140	115	95j6	M8	24j6	50	8h9	27	10	3	120	95	120	352
SE(M)KhR90-L1	B14/C1	160	130	110j6	M8	24j6	50	8h9	27	10	3,5	-	95	120	337
SEKhR90-LF1	B14/C1	160	130	110j6	M8	24j6	50	8h9	27	10	3,5	120	95	120	377
SE(M)KhR90-L2	B14/C2	140	115	95j6	M8	24j6	50	8h9	27	10	3	-	95	120	337
SEKhR90-LF2	B14/C2	140	115	95j6	M8	24j6	50	8h9	27	10	3	120	95	120	377
SE(M)KhR90-M1	B14/C1	160	130	110j6	M8	24j6	50	8h9	27	10	3,5	-	95	120	357
SEKhR90-MF1	B14/C1	160	130	110j6	M8	24j6	50	8h9	27	10	3,5	120	95	120	397
SE(M)KhR90-M2	B14/C2	140	115	95j6	M8	24j6	50	8h9	27	10	3	-	95	120	357
SEKhR90-MF2	B14/C2	140	115	95j6	M8	24j6	50	8h9	27	10	3	120	95	120	397

DIMENSION DRAWINGS





**CANTONI**  
**MOTOR**



ISO 9001

**CANTONI MOTOR S.A.**  
**M. Grażyńskiego 22**  
**43-300 Bielsko-Biała, Poland**  
**tel.: +48 33 813 87 00**  
**fax: +48 33 813 87 01**  
**[motor@cantonigroup.com](mailto:motor@cantonigroup.com)**  
**[www.cantonimotor.com](http://www.cantonimotor.com)**